

## INDEX

### SECTION B:4

### MECHANICS TYPE "R" SERIES

SERIES	SECTION
17R.....	B:4-3
2R.....	B:4-7
21R.....	B:4-11
25R.....	B:4-15
3R.....	B:4-17
MID SHIP ASSEMBLIES.....	B:4-21
TRIPOD STYLE.....	B:4-23

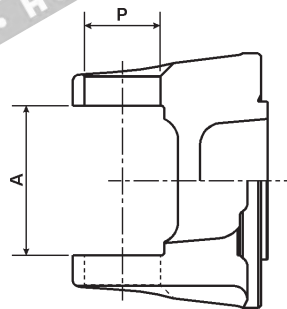

### UNIVERSAL JOINT TORQUE CAPACITIES

SERIES	P	A	CONTINUOUS OPERATION eg. PETROL or DIESEL ENGINE	INDUSTRIAL OPERATION eg. ELECTRIC MOTOR DRIVE	SHORT DURATION TORQUE
<b>17R</b>	25.40	43.64	169.0 Nm	253.0 Nm	847.0 Nm
	1.000	1.718	124.0 ft/lbs	186.6 ft/lbs	624.6 ft/lbs
<b>2R</b>	25.40	59.44	217.0 Nm	325.0 Nm	1085.0 Nm
	1.000	2.340	160.0 ft/lbs	239.7 ft/lbs	800.1 ft/lbs
<b>21R/21S</b>	27.39	54.00	238.0 Nm	357.0 Nm	1191.0 Nm
	1.078	2.125	175.5 ft/lbs	263.3 ft/lbs	878.3 ft/lbs
<b>25R</b>	28.57	59.44	380.0 Nm	569.0 Nm	1898.0 Nm
	1.125	2.340	280.2 ft/lbs	419.6 ft/lbs	1399.7 ft/lbs
<b>3R</b>	28.57	65.10	237.0 Nm	352.5 Nm	1185.0 Nm
	1.125	2.563	175.0 ft/lbs	260.0 ft/lbs	875.0 ft/lbs

www.hardyspicer.com.au

Document No:	HSDSCAT
Issue:	9
Issue Date:	18/07/19



[www.hardyspicer.com.au](http://www.hardyspicer.com.au)

Document No:	HSDSCAT
Issue:	9
Issue Date:	18/07/19

## MECHANICS TYPE 17R

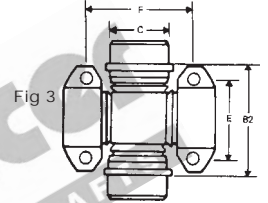
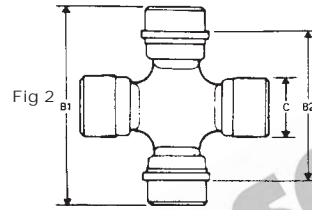
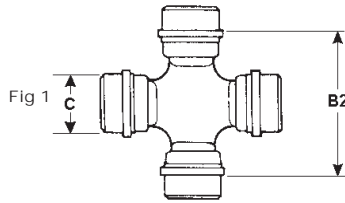

### 17R STANDARD UNIVERSAL JOINT

PART No.	FIG	C	B2	LUBE	DESCRIPTION
<i>RUJ-1786</i>	1	25.40	43.64	CAP	STANDARD JOINT
<i>RUJ-1786R</i>	1	25.40	43.64	NIL	PREMIUM THRUST WASHER TYPE

### 17R CONVERSION UNIVERSAL JOINT

PART No.	FIG	C	B1	B2	E	F	LUBE	DESCRIPTION
<i>RUJ-1766</i>	2	23.80 25.40	61.30	43.64			CAP	1140 SERIES TO 17R SERIES
<i>RUJ-1768</i>	3	25.40		43.64	33.34	44.45	NIL	JOHN DEERE
<i>RUJ-1758</i>	3	25.40		43.64	33.34	52.78	CAP	EARLY HOLDEN
<i>5-248X</i>	2	25.40 26.99	61.93	43.64			CENTRE	17R SERIES TO 1110 SERIES

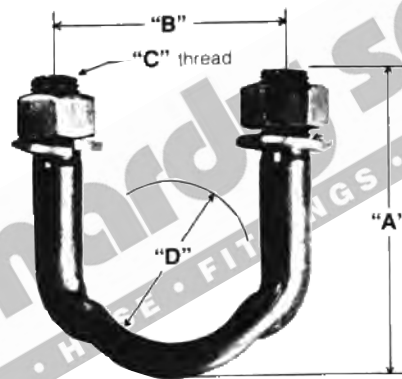

Fig 4

### U/BOLT KIT

PART No.	FIG	U-BOLTS or CLAMPS	LOCK WASHER	HEX NUT or CAP SCREW	A	B	C	D	SUITS SHAFT SERIES
<b>104</b>	4	2	4	4	47.62 1.875	34.92 1.375	1/4-28UNF	25.40 1.000	17R 2 x U/Bolts, 4 x nuts, 4 x S/Washers

www.hardyspicer.com.au

Document No:	HSDSCAT
Issue:	9
Issue Date:	18/07/19

## 17R MECHANICS TYPE

A = 43.64  
1.718  
P = 25.40  
1.000

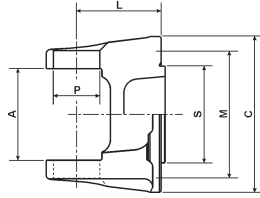

## 17R FLANGE YOKE

PART No.	FLANGE DIA.	C/L OF U.J. TO FACE	SPIGOT DIA M=MALE F=FEMALE	P.C.D.	BOLT HOLE PATTERN	No. HOLES	HOLE DIA	DESCRIPTION
	C	L	S	M				
17R-2-431C	81.00 3.189	43.00 1.690	M-44.90 1.768	89.09 3.507	63.00 x 63.00 2.480 x 2.480	4	8.50 0.335	MAZDA
17R-2-502	90.00 3.543	43.00 1.690	M-44.90 1.768	73.00 2.874	45.70 x 56.70 1.799 x 2.232	4	8.30 0.327	MAZDA
17R-2-504	90.00 3.543	43.00 1.690	M-44.90 1.768	74.50 2.933	46.00 x 59.00 1.810 x 2.323	4	8.30 0.327	MAZDA ROTARY
17R-2-608			M-60.00 2.362		60.80 x 51.40 2.394 x 2.024	4	8.20 0.323	mitsubishi EVO LANCER AWD
17R-2-423C	103.17 4.062	40.00 1.575	M-46.00 1.810	77.83 3.064	54.80 x 54.80 2.157 x 2.157	4	8.20 0.323	TOYOTA
17R-2-439C	108.00 4.251	43.00 1.693	M-46.00 1.810	84.85 3.341	60.00 x 60.00 2.362 x 2.362	4	10.20 0.402	TOYOTA
17R-2-500	92.00 3.622	39.00 1.535	M-50.00 1.969	75.80 2.984	53.60 x 53.60 2.110 x 2.110	4	8.50 0.335	SUBARU / NISSAN
17R-2-501	92.00 3.622	39.00 1.535	M-50.00 1.969	75.00 2.853	48.00 x 58.00 1.890 x 2.283	4	8.50 0.335	NISSAN (CENTRE)
17R-2-1309	102.50 4.251	43.00 1.693	M-50.00 1.969	81.28 3.200	57.50 x 57.50 2.264 x 2.264	4	10.50 0.413	NISSAN NOMAD / 300ZX
17R-2-445	108.00 4.251	41.00 1.614	M-56.00 2.204	89.90 3.539	67.00 x 60.00 2.638 x 2.362	4	10.50 0.413	ENGLISH FORD
17R-2-429	87.00 3.425	38.00 1.496	M-57.15 2.250	69.88 2.751	44.91 x 53.50 1.768 x 2.106	4	8.50 0.335	NISSAN / 1140 SERIES
17R-2-437	92.00 3.622	38.00 1.496	M-57.09 2.125	77.83 3.064	67.40 x 38.92 2.654 x 1.532	4	10.60 0.417	HOLDEN / MITSUBISHI NISSAN
17R-2-SF-S	92.30 3.634	40.00 1.575	M-58.30 2.295	N/A	N/A	N/A		SEMI FINISHED FULL ROUND
17R-2-SF-L	108.00 4.251	40.00 1.575	M-58.30 2.295	N/A	N/A	N/A		SEMI FINISHED FULL ROUND

www.hardyspicer.com.au

Document No:	HSDSCAT
Issue:	9
Issue Date:	18/07/19

## MECHANICS TYPE 17R

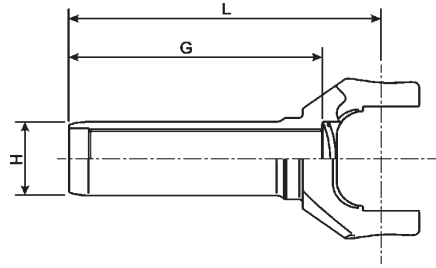

17R

SLIP YOKE

PART No.	No. OF SPLINES	SPLINE		GROUND SLEEVE DIA. H	C/L TO END L	LENGTH OF HOLE G	COMMENTS
		MAJOR DIA.	MINOR DIA.				
17R-3-1628	11-INV	24.99 0.984	21.33 0.840	34.87 1.373	132.00 5.197	105.02 4.135	HOLDEN 3 SPEED NON SYNCRO
17R-3-1848	16-INV	22.28 0.877	18.80 0.740	30.13 1.186	140.40 5.528	115.00 4.528	FORD ESCORT AUST. PRODUCTION AVAILABLE WHILE STOCKES LAST
17R-3-1498	18-INV	20.50 0.807	17.98 0.708	29.93 1.178	122.20 4.811	96.80 3.811	DATSUN 120Y, 1200, SUNNY, C20
17R-3-1358	20-INV	22.80 0.898	20.10 0.791	30.13 1.186	140.40 5.528	115.00 4.528	FORD CORTINA & ESCORT AUST. PRODUCTION
17R-3-2188	20-INV	22.83 0.899	20.70 0.815	31.95 1.258	142.00 5.591	116.60 4.591	TOYOTA COROLLA KE30/35
17R-3-2522	21-INV	24.10 0.945	21.40 0.843	32.00 1.260	136.20 5.354	108.00 4.252	MITSUBISHI EVO LANCER AWD
17R-3-1478	21-INV	27.96 1.101	25.58 1.007	37.97 1.495	145.20 5.717	115.05 4.530	TOYOTA 5 SPEED
17R-3-2638	22-INV	25.34 0.998	22.47 0.885	31.95 1.258	142.00 5.591	116.60 4.591	TOYOTA
17R-3-2158	22-INV	25.40 1.000	22.22 0.875	34.90 1.374	150.00 5.906	119.58 4.719	MAZDA ROTARY / PISTON UP TO 1984
17R-3-1308	24-INV	25.52 1.005	23.00 0.906	34.95 1.376	148.40 5.843	118.25 4.656	NISSAN
17R-3-2498	24-INV	26.92 1.060	24.35 0.959	35.92 1.414	132.00 5.197	105.02 4.135	V.K. COMMODORE 5 SPEED
17R-3-1518	25-INV	28.27 1.113	24.97 0.983	34.91 1.374	140.40 5.528	111.82 4.402	FORD ESCORT / CORTINA CAPRI AUST. PRODUCTION
17R-3-1158	25-INV	28.27 1.113	24.97 0.983	34.86 1.372	149.80 5.898	119.65 4.711	FORD FALCON SUPERCEDED TO 17R-3-1518
17R-3-1188	27-INV	30.23 1.190	27.94 1.100	38.15 1.502	133.00 5.236	105.20 4.141	HOLDEN AUTO / MANUAL VK COMMODORE

www.hardyspicer.com.au

Document No:	HSDSCAT
Issue:	9
Issue Date:	18/07/19

**17R MECHANICS TYPE**

BUTT TYPE  
H=HOLLOW  
S=SOLID

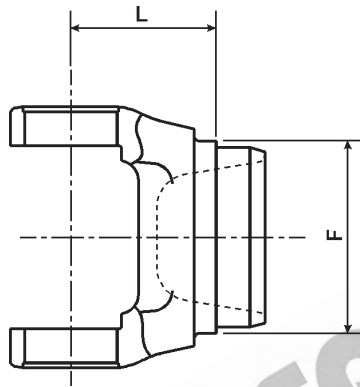

**17R WELD YOKE**

PART No.	C/LINE TO POINT OF WELD L	TUBE O.D. & WALL THICKNESS F	TUBE PART No.	BUTT TYPE	COMMENTS
17R-26-330	41.00 1.614	50.80 x 2.41 2.000 x 0.095	1613-0000	S	
17R-26-328	43.00 1.693	57.15 x 1.65 2.250 x 0.065	1816-0000	H	
17R-26-231	41.00 1.614	63.50 x 1.65 2.500 x 0.065	2016-0000	H	
17R-26-350	31.20 1.228	69.85 x 1.65 2.750 x 0.065	2216-0000	H	
17R-26-261	43.00 1.693	76.20 x 1.65 3.000 x 0.065	2416-0000	H	

Reference Only

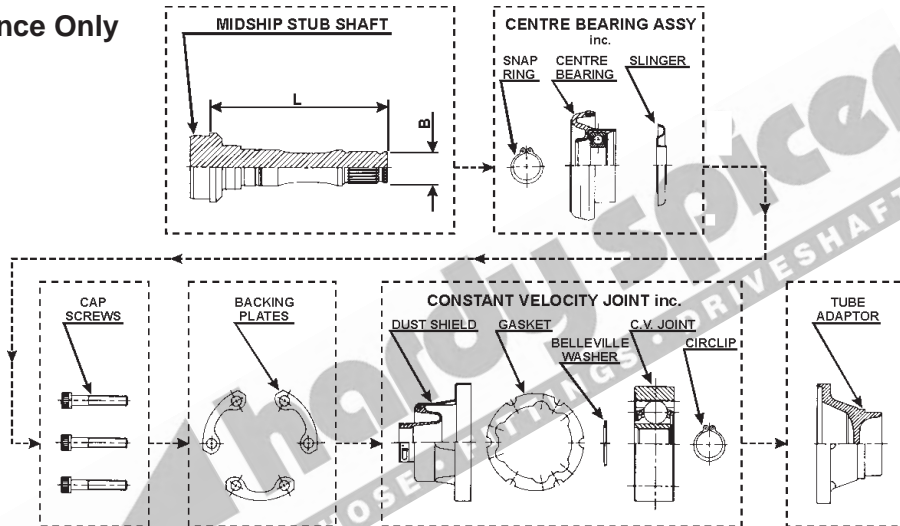

**17R MID SHIP ASSEMBLY**

MIDSHIP STUB SHAFT PART No.	SPLINE DIA. & No. B	END OF SPLINE TO POINT OF WELD L	TUBE PART No. & SIZE	BEAR-ING I.D. 1.181	CENTRE BEAR-ING PART No. CB-952	CV JOINT CV-856	TUBE ADAPTOR PART No. 679-R08	COMMENTS
17R-56-5821 NLA	26.46-24 1.042	144.00 5.669	1813-0000 2.250 x 0.095	30.00 1.181	CB-952	CV-856	679-R08 NLA	CAP SCREW 6 x 608-R95 + BACKING PLATE 3 x 806-R15

Note : Replacement Boot Kit Only = CV-852

www.hardyspicer.com.au

Document No:	HSDSCAT
Issue:	9
Issue Date:	18/07/19

## MECHANICS TYPE 2R

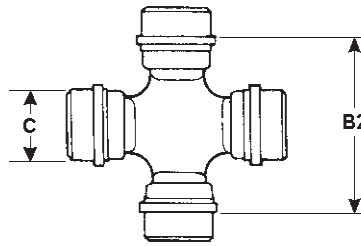

Fig 1

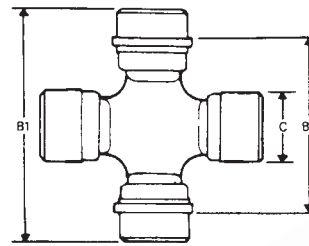

Fig 2

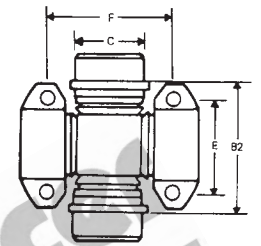

Fig 3

### 2R STANDARD UNIVERSAL JOINT

PART No.	FIG	C	B2	LUBE	DESCRIPTION
<i>RUJ-2030</i>	1	25.40	59.53	NIL	STANDARD JOINT
<i>RUJ-2030R</i>	1	25.40	59.53	NIL	PREMIUM THRUST WASHER TYPE
<i>114-2101</i>	1	25.40	59.53	CAP	GREASABLE CAP

### 2R CONVERSION UNIVERSAL JOINT

PART No.	FIG	C	B1	B2	E	F	LUBE	DESCRIPTION
<i>114-2111</i>	3	25.40		59.53	33.34	59.53	SIDE OR CAP	2R SERIES TO 2C MECHANICS
<i>114-2107</i>	3	25.40		43.64	33.34	61.52	SIDE	2R SERIES
<i>RUJ-2032</i>	2	25.40 26.99	81.76	59.53			SIDE	2R SERIES TO 1310 SERIES
<i>RUJ-2009</i>	1	25.40 28.58		59.53 59.53			SIDE	2R SERIES TO 25R SERIES
<i>RUJ-2034</i>	2	25.40 28.58	81.76	59.53			SIDE	2R SERIES TO 25R SERIES

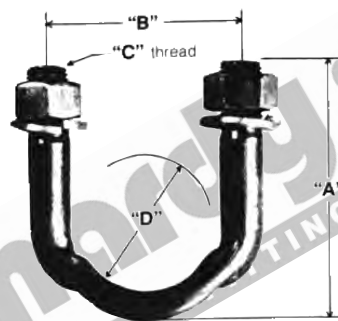

Fig 4

### U/BOLT KIT

PART No.	FIG	U-BOLTS	LOCK WASHER	HEX NUT or CAP SCREW	A	B	C	D	SUITS SHAFT SERIES
<i>2R-94-10</i>	4	2	4	4	60.30 2.375	34.92 1.375	1/4-28UNF	25.40 1.000	2R 2 x U/Bolts, 4 x nuts, 4 x S/Washers
<i>102</i>	4	2	4	4	47.62 1.875	35.72 1.406	5/16-24UNF	26.99 1.038	9" Yokes - 1-1/16" CAPS
<i>105</i>	4	2	4	4	50.00 1.969	40.48 1.594	5/16-18UNF	28.57 1.125	9" Yokes - 1-1/8" CAPS

www.hardyspicer.com.au

Document No:	HSDSCAT
Issue:	9
Issue Date:	18/07/19

## 2R MECHANICS TYPE

C = 25.40  
 1.000  
 B2 = 59.44  
 2.340

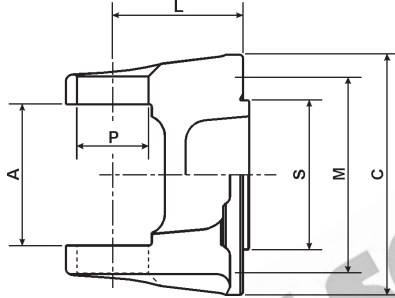

## 2R FLANGE YOKE

PART No.	FLANGE DIA.	C/L OF U.J. TO FACE	SPIGOT DIA M=MALE F=FEMALE	P.C.D.	BOLT HOLE PATTERN	No. HOLES	HOLE DIA	DESCRIPTION
	C	L	S		M			
2R-2-438	92.00 3.662	38.00 1.496	M-57.00 2.244	77.83 3.064	30° SPACING	4	10.50 0.417	COMMODORE / NISSAN

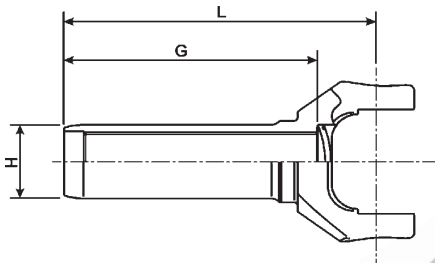

## 2R SLIP YOKE

PART No.	No. OF SPLINES	SPLINE		GROUND SLEEVE DIA. H	C/L TO END L	LENGTH OF HOLE G	COMMENTS
		MAJOR DIA.	MINOR DIA.				
2R-3-3188	21-INV	27.96 1.101	25.58 1.007	37.97 1.495	145.20 5.717	115.05 4.530	TOYOTA 5 SPEED
2R-3-1278	27-INV	30.22 1.190	27.94 1.100	38.15 1.502	148.40 5.843	113.50 4.469	HOLDEN 253 V8 UP TO VK COMMODORE
2R-3-2398	28-INV	30.70 1.209	27.76 1.093	38.02 1.497	156.40 6.157	124.65 4.907	FORD TRANSIT, FORD 28 SPLINE RAMBLER
2R-3-2938	30-INV	32.62 1.284	30.00 1.181	41.95 1.652	155.00 6.102	125.00 4.921	COMMODORE VL TURBO MANUAL NISSAN 300ZX

www.hardyspicer.com.au

Document No:	HSDSCAT
Issue:	9
Issue Date:	18/07/19



## MECHANICS TYPE 2R

BUTT TYPE  
H=HOLLOW  
S=SOLID

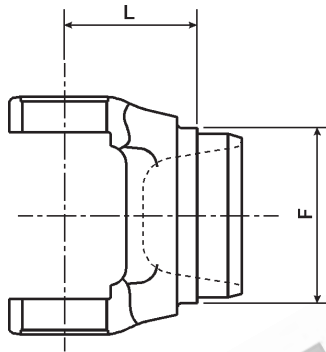

## 2R

## WELD YOKE

PART No.	C/LINE TO POINT OF WELD L	TUBE O.D. & WALL THICKNESS F	TUBE PART No.	BUTT TYPE	COMMENTS
2R-26-295	43.00 1.693	57.15 x 2.41 2.250 x 0.095	1813-0000	H	
2R-26-212	48.00 1.890	63.50 x 1.65 2.500 x 0.065	2016-0000	H	
2R-26-234	47.00 1.850	69.85 x 1.65 2.750 x 0.065	2216-0000	H	
2R-26-224	52.00 2.047	76.20 x 1.65 3.000 x 0.065	2416-0000	H	

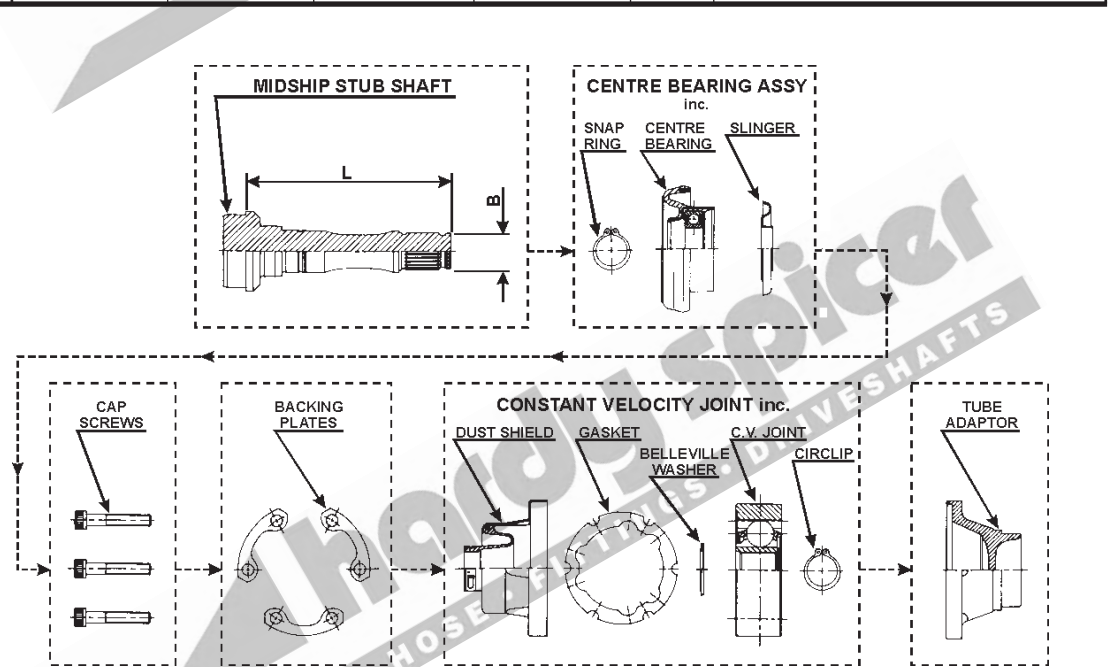

## 2R

## MID SHIP ASSEMBLY

MIDSHIP STUB SHAFT PART No.	SPLINE DIA. & No. B	END OF SPLINE TO POINT OF WELD L	TUBE PART No. & SIZE	BEAR-ING I.D. 1.181	CENTRE BEAR-ING PART No. CB-952	CV JOINT CV-855A	TUBE ADAPTOR PART No. 679-R09	COMMENTS
2R-56-5861	27.50-25 1.083	138.00 5.433	1813-0000 2.250 x 0.095	30.00 1.181	CB-952	CV-855A	679-R09	CAP SCREW 6 x 608-R95 + BACKING PLATE 3 x 806-R16

Note : Replacement Boot Kit Only = CV-853

www.hardyspicer.com.au

Document No:	HSDSCAT
Issue:	9
Issue Date:	18/07/19



[www.hardyspicer.com.au](http://www.hardyspicer.com.au)

Document No:	HSDSCAT
Issue:	9
Issue Date:	18/07/19

## MECHANICS TYPE 21R

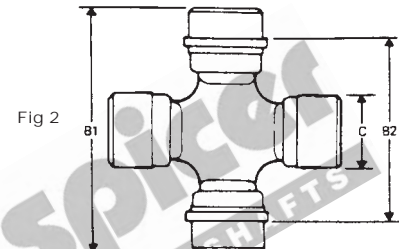
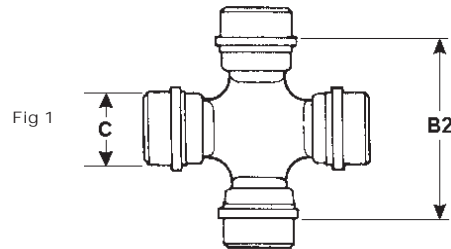

### 21R STANDARD UNIVERSAL JOINT

PART No.	FIG	C	B2	LUBE	DESCRIPTION
<i>RUJ-2038</i>	1	27.39	54.00	NIL	STANDARD JOINT
<i>RUJ-2038R</i>	1	27.39	54.00	NIL	PREMIUM THRUST WASHER TYPE

### 21R CONVERSION UNIVERSAL JOINT

PART No.	FIG	C	B1	B2	E	F	LUBE	DESCRIPTION
<i>K5-A530</i>	2	26.99 27.39	81.76	54.00			SIDE	1310 SERIES TO 21R SERIES
<i>RUJ-2029</i>	2	27.39 28.58	82.00	54.00			SIDE	21R SERIES TO 8.5" SERIES FORD DIFF

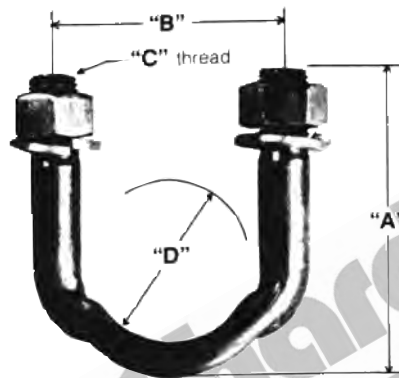

Fig 4

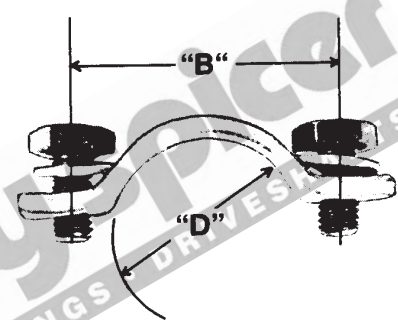

Fig 5

"C" = Hex Head Cap Screw Size

### STRAP & U/BOLT KIT

PART No.	FIG	STRAPS	LOCK WASHER	CAP SCREW	A	B	C	D	SUITS SHAFT SERIES
<b>106</b>	5	2	4	4		38.10 1.500	1/4-28	27.39 1.078	21R
<b>102</b>	4	2	4	4	47.62 1.875	35.72 1.406	5/16-24UNF	26.99 1.038	9" Yokes - 1-1/16" CAPS
<b>105</b>	4	2	4	4	50.00 1.969	40.48 1.594	5/16-18UNF	28.57 1.125	9" Yokes - 1-1/8" CAPS

www.hardyspicer.com.au

Document No:	HSDSCAT
Issue:	9
Issue Date:	18/07/19

## 21R MECHANICS TYPE

A = 54.00  
 2.126  
 P = 27.39  
 1.078

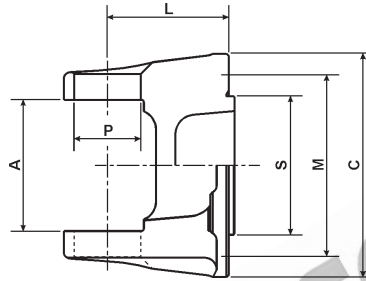

## 21R FLANGE YOKE

PART No.	FLANGE DIA.	C/L OF U.J. TO FACE		SPIGOT DIA M=MALE F=FEMALE	P.C.D.	BOLT HOLE PATTERN	No. HOLES	HOLE DIA	DESCRIPTION
		C	L						
<b>21R-2-503</b>	90.00 3.543	43.00 1.690		M-44.97 1.770	73.00 2.874	45.70 x 56.70 1.799 x 2.232	4	8.30 0.327	MAZDA
<b>21R-2-505</b>	90.00 3.543	43.00 1.690		M-44.97 1.770	74.50 2.933	46.00 x 59.00 1.810 x 2.323	4	8.30 0.327	MAZDA ROTARY
<b>21S-2-455</b>	107.00 4.212	40.00 1.575		M-44.97 1.770	89.08 3.507	63.00 x 63.00 2.480 x 2.480	4	8.30 0.327	MAZDA
<b>21S-2-453</b>	119.00 4.685	40.00 1.575		M-44.97 1.770	96.16 3.786	68.00 x 68.00 2.677 x 2.677	4	10.15 0.400	MAZDA
<b>21S-2-452</b>	128.00 5.039	40.00 1.575		M-44.97 1.770	104.70 4.122	74.00 x 74.00 2.913 x 2.913	4	10.15 0.400	MAZDA
<b>21R-2-501</b>	92.00 3.622	40.00 1.575		M-50.00 1.969	75.00 2.953	48.00 x 58.00 1.889 x 2.283	4	8.50 0.335	NISSAN 300ZX (CENTRE)
<b>21R-2-1309</b>	102.50 4.251	43.00 1.693		M-50.00 1.969	81.28 3.200	57.50 x 57.50 2.264 x 2.264	4	10.50 0.413	NISSAN 300ZX (REAR)
<b>21R-2-456</b>	109.50 4.311	46.00 1.811		F-50.83 2.001	88.90 3.500	62.90 x 62.90 2.476 x 2.476	4	10.68 0.420	GM INDONESIA
<b>21R-2-460</b>	109.50 4.311	46.00 1.811		F-50.83 2.001	88.90 3.500	62.90 x 62.90 2.476 x 2.476	4	12.90 0.508	FALCON NLA USE 21R-2-456 DRILL HOLES
<b>21R-2-444</b>	92.00 3.662	38.00 1.496		M-57.00 2.244	77.83 3.025	67.40 x 38.92 2.653 x 1.532	4	10.50 0.413	COMMODORE
<b>21R-2-446</b>	92.00 3.662	50.00 1.968		M-57.00 2.244	77.83 3.025	67.40 x 38.92 2.653 x 1.532	4	10.50 0.413	COMMODORE IRS
<b>21R-2-457</b>	96.82 3.812	30.15 1.187		M-60.33 2.375	79.38 3.125	60.80 x 51.02 2.394 x 2.009	4	9.68 0.381	21R TO 1310 FACE
<b>21R-2-SF</b>	108.50 4.272	40.00 1.575		M-58.50 2.303	N/A	N/A	N/A	N/A	SEMI FINISHED FULL ROUND

www.hardyspicer.com.au

Document No:	HSDSCAT
Issue:	9
Issue Date:	18/07/19

## MECHANICS TYPE 21R

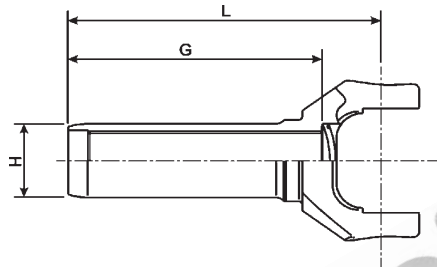

### 21R

### SLIP YOKE

PART No.	No. OF SPLINES	SPLINE		GROUND SLEEVE DIA. H	C/L TO END L	LENGTH OF HOLE G	COMMENTS
		MAJOR DIA.	MINOR DIA.				
21R-3-3408	16-STR	38.10 1.500	33.00 1.300	N/A	145.70 5.736	117.80 4.638	1350 SPLINE WITH DUST CAP
21R-3-3208	21-INV	27.96 1.101	25.58 1.007	37.97 1.475	145.20 5.717	115.05 4.530	TOYOTA 5 SPEED
21S-3-3328	22-INV	25.40 1.000	22.22 0.875	34.92 1.375	145.00 5.709	116.00 4.567	MAZDA, EARLY MODELS
21R-3-3558	23-INV	30.48 1.200	28.50 1.122	39.95 1.573	156.70 6.169	112.00 4.409	TOYOTA SUPRA TURBO
21R-3-3138	24-INV	25.52 1.005	23.00 0.906	34.95 1.376	155.00 6.102	127.00 5.000	SKYLINE MANUAL
21S-3-3318	25-INV	28.27 1.113	25.11 0.989	37.93 1.493	152.00 5.984	123.00 4.843	MAZDA LATE MODEL
21R-3-3548	25-INV	28.27 1.113	25.11 0.989	34.93 1.375	152.00 5.984	125.00 4.921	FORD TRANSIT
21R-3-3140	26-INV	28.52 1.123	26.00 1.024	37.95 1.494	155.00 6.102	126.00 4.961	VL COMMODORE AUTO SKYLINE AUTO
21S-3-3288	26-INV	29.41 1.158	26.60 1.047	39.68 1.562	174.00 6.850	145.50 5.728	CHRYSLER
21R-3-3168	27-INV	30.23 1.190	27.94 1.100	38.15 1.502	155.00 6.102	126.00 4.961	COMMODORE VN AUTO TURBO 700, T56 VT GEN3 6SPD MAN
21R-3-3158	28-INV	30.98 1.220	27.76 1.093	38.02 1.497	155.00 6.102	126.00 4.961	FORD MANUAL / AUTO C4, C10, T5, VT 5.0L 5SPD MAN 4SPD AUTO, COMMODORE VN MAN
21S-3-3248	30-INV	33.53 1.320	30.73 1.210	42.65 1.680	204.00 8.031	175.00 6.890	VALIANT TORQUE FLIGHT 29 BASED ON 30
21R-3-3738	30-INV	32.61 1.284	30.00 0.000	42.00 1.652	154.00 6.063	124.00 4.882	NISSAN 300ZX / VL COMMODORE TURBO
21R-3-3098	31-INV	35.33 1.391	32.10 1.264	42.85 1.687	157.00 6.181	126.30 4.927	FORD C6, FMX, TOPLOADER ONLY

www.hardyspicer.com.au

Document No:	HSDSCAT
Issue:	9
Issue Date:	18/07/19

## 21R MECHANICS TYPE

BUTT TYPE  
H=HOLLOW  
S=SOLID

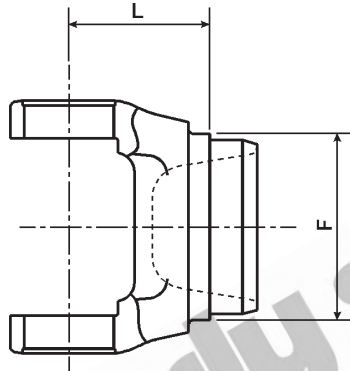

## 21R WELD YOKE

PART No.	C/LINE TO POINT OF WELD L	TUBE O.D. & WALL THICKNESS F	TUBE PART No.	BUTT TYPE	COMMENTS
21R-26-361	43.00 1.693	57.15 x 2.41 2.250 x 0.095	1813-0000	H	
21R-26-373	43.00 1.693	65.00 x 1.60 2.560 x 0.063	2016-0000	H	
21S-26-363	37.60 1.480	69.85 x 1.65 2.750 x 0.065	2216-0000	H	
21R-26-357	38.00 1.496	76.20 x 1.65 3.000 x 0.065	2416-0000	H	
21R-26-356	38.00 1.496	82.55 x 1.65 3.250 x 0.065	2615-0000	H	

## 21R MID SHIP ASSEMBLY

**Note : Commodore / Skyline Applications Use  
17R or 2R Mid Ship Assembly  
For Performance Applications Use FD- Mid Ship Assemblies.  
Refer Page B4:21**

www.hardyspicer.com.au

Document No:	HSDSCAT
Issue:	9
Issue Date:	18/07/19

## MECHANICS TYPE 25R

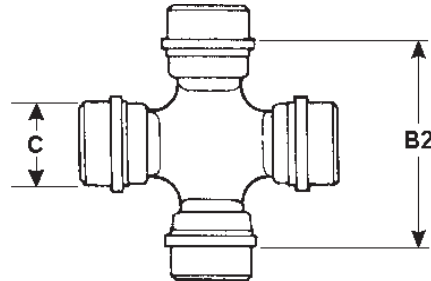

Fig 1

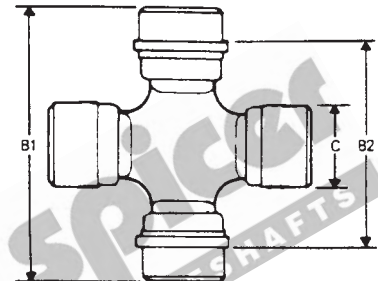

Fig 2

### 25R STANDARD UNIVERSAL JOINT

PART No.	FIG	C	B2	LUBE	DESCRIPTION
<i>RUJ-2500</i>	1	28.58	59.53	NIL	STANDARD JOINT
<i>RUJ-2500R</i>	1	28.58	59.53	NIL	PREMIUM THRUST WASHER TYPE
<i>RUJ-2503</i>	1	28.58	59.53	CAP	GREASABLE

### 25R CONVERSION UNIVERSAL JOINT

PART No.	FIG	C	B1	B2	E	F	LUBE	DESCRIPTION
<i>RUJ-2502</i>	2	28.58 26.99	81.76	59.53			NIL	25R SERIES TO 1310 SERIES

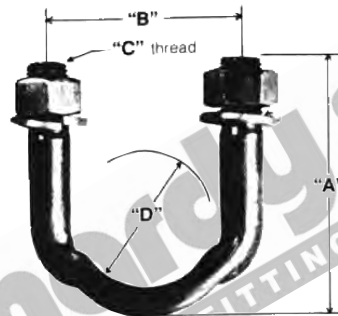

Fig 4

### U/BOLT KIT

PART No.	FIG	U-BOLTS	LOCK WASHER	HEX NUT	A	B	C	D	SUITS SHAFT SERIES
<i>25R-94-11</i>	4	2	4	4	62.00 2.441	39.70 1.562	5/16-24UNF	28.58 1.125	25R 2 x U/Bolts, 4 x nuts, 4 x S/Washers
<i>102</i>	4	2	4	4	47.62 1.875	35.72 1.406	5/16-24UNF	26.99 1.038	9" Yokes - 1-1/16" CAPS
<i>105</i>	4	2	4	4	50.00 1.969	40.48 1.594	5/16-18UNC	28.57 1.125	9" Yokes - 1-1/8" CAPS

www.hardyspicer.com.au

Document No:	HSDSCAT
Issue:	9
Issue Date:	18/07/19

25R MECHANICS TYPE

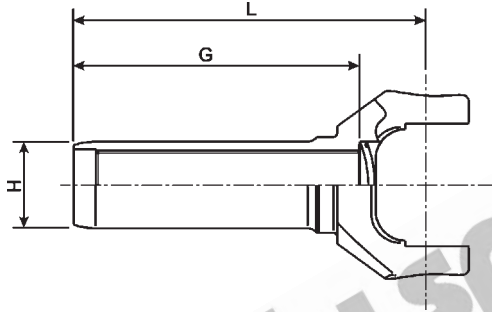

25R SLIP YOKE

PART No.	No. OF SPLINES	SPLINE		GROUND SLEEVE DIA. H	C/L TO END L	LENGTH OF HOLE G	COMMENTS
		MAJOR DIA.	MINOR DIA.				
25R-3-1908	14-INV	31.80 1.252	27.58 1.068	41.25 1.624	90.47 3.562	58.72 2.312	JOHN DEERE
25R-3-3308	16	34.84 1.372	30.18 1.188	44.73 1.761	181.32 7.139	148.73 5.856	SUITS 1310 SPICER STUB
25R-3-1488	27-INV	30.22 1.190	27.94 1.100	38.15 1.502	149.20 5.874	116.67 4.593	HOLDEN 1 TONNE
25R-3-1538	32-INV	35.48 1.397	33.20 1.307	47.87 1.885	182.30 7.177	148.20 5.835	HOLDEN 350 V8 AUTO TURBO 400

BUTT TYPE  
H=HOLLOW  
S=SOLID

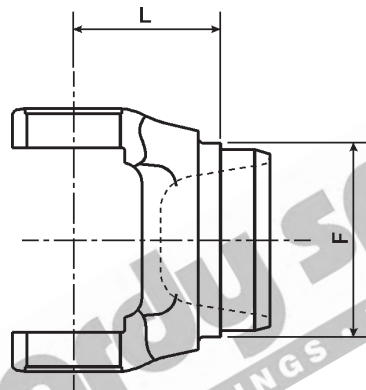

25R WELD YOKE

PART No.	C/LINE TO POINT OF WELD L	TUBE O.D. & WALL THICKNESS F	TUBE PART No.	BUTT TYPE	COMMENTS
25R-26-296	41.00 1.614	57.15 x 2.41 2.250 x 0.095	1813-0000	H	
25R-26-222	46.00 1.811	63.50 x 1.65 2.500 x 0.065	2016-0000	H	
25R-26-215	46.00 1.811	69.85 x 1.65 2.750 x 0.065	2216-0000	H	
25R-26-216	46.00 1.811	76.20 x 1.65 3.000 x 0.065	2416-0000	H	

www.hardyspicer.com.au

Document No:	HSDSCAT
Issue:	9
Issue Date:	18/07/19



## MECHANICS TYPE 3R

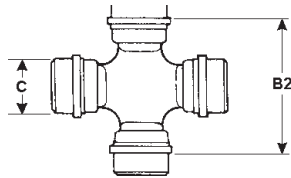

Fig 1

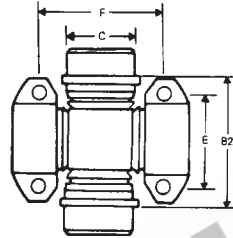

Fig 2

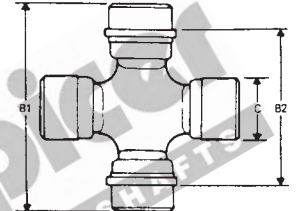

Fig 3

### 3R STANDARD UNIVERSAL JOINT

PART No.	FIG	C	B2	LUBE	DESCRIPTION
114-3105	1	28.58	65.10	SIDE	STANDARD JOINT
114-3105HD	1	28.58	65.10	SIDE	SOLID CROSS HEAVY DUTY JOINT

### 3R CONVERSION UNIVERSAL JOINT

PART No.	FIG	C	B1	B2	E	F	LUBE	DESCRIPTION
114-3102	2	28.58		65.10	36.52	69.85	SIDE	3R SERIES TO 3C SERIES
114-596	3	26.99 28.58	92.08	65.10			SIDE	1330 SERIES TO 3R SERIES

\* If a NEW shaft is required use 1310 Series or 1330 Series preferred.

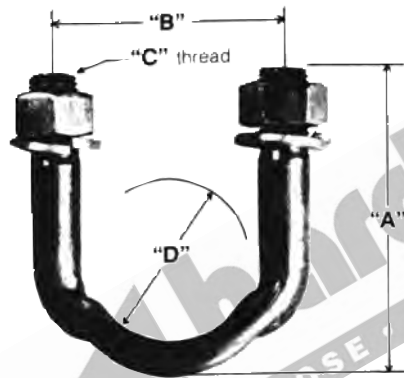

Fig 4

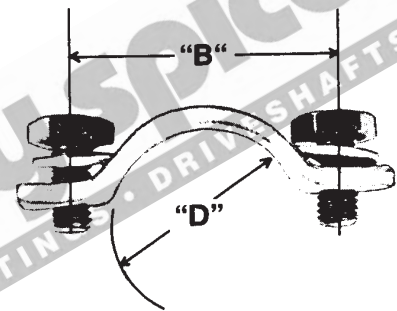

Fig 5

"C" = Hex Head Cap Screw Size

### STRAP & U/BOLT KIT

PART No.	FIG	STRAPS	LOCK WASHER	CAP SCREW	A	B	C	D	SUITS SHAFT SERIES
108	5	2	4	4		46.04 1.812	5/16-24	28.57 1.125	3R
102	4	2	4	4	47.62 1.875	35.72 1.406	5/16-24UNF	26.99 1.038	9" Yokes - 1-1/16" CAPS
105	4	2	4	4	50.00 1.969	40.48 1.594	5/16-18UNF	28.57 1.125	9" Yokes - 1-1/8" CAPS

www.hardyspicer.com.au

Document No:	HSDSCAT
Issue:	9
Issue Date:	18/07/19

## 3R MECHANICS TYPE

C = 28.58  
 1.125  
 B2 = 65.10  
 2.563

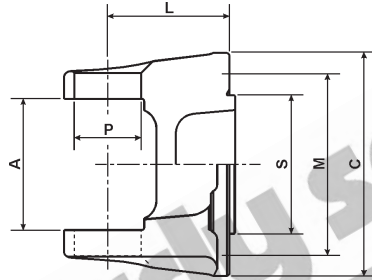

## 3R FLANGE YOKE

PART No.	FLANGE DIA.	C/L OF U.J. TO FACE	SPIGOT DIA M=MALE F=FEMALE	P.C.D.	BOLT HOLE PATTERN	No. HOLES	HOLE DIA	DESCRIPTION
	<b>C</b>	<b>L</b>	<b>S</b>		<b>M</b>			
<b>3R-2-8268</b>	125.48 4.940	42.93 1.690	F-79.37 3.125	107.95 4.250	76.20 x 76.20 3.000 x 3.000	4	11.38 0.448	

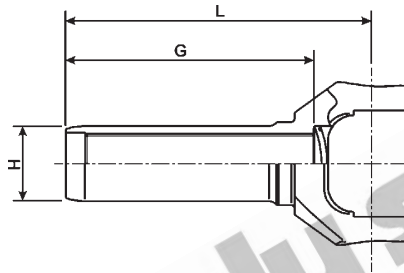

## 3R SLIP YOKE

PART No.	No. OF SPLINES	SPLINE		GROUND SLEEVE DIA. H	C/L TO END L	LENGTH OF HOLE G	COMMENTS
		MAJOR DIA.	MINOR DIA.				
<b>3R-3-6081X</b>	27-INV	30.22 1.190	27.94 1.100	38.15 1.502	138.94 5.470	116.59 4.590	TURBO 350 / 700
<b>3R-3-9131X</b>	32-INV	35.48 1.397	33.20 1.307	47.87 1.885	190.50 7.500	165.10 6.500	TURBO 400

www.hardyspicer.com.au

Document No:	HSDSCAT
Issue:	9
Issue Date:	18/07/19

## MECHANICS TYPE 3R

BUTT TYPE  
H=HOLLOW  
S=SOLID

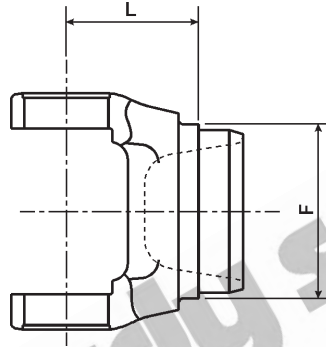

### 3R

### WELD YOKE

PART No.	C/LINE TO POINT OF WELD L	TUBE O.D. & WALL THICKNESS F	TUBE PART No.	BUTT TYPE	COMMENTS
<b>3R-28-307</b>	44.45 1.750	69.85 x 1.65 2.750 x 0.065	<b>2216-0000</b>	H	
<b>3R-28-327</b>	47.75 1.880	76.20 x 1.65 3.000 x 0.065	<b>2416-0000</b>	H	

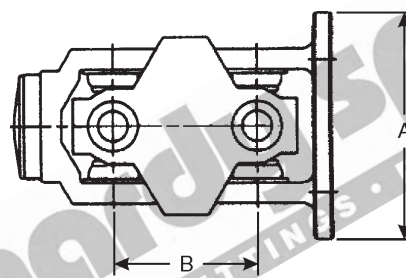

### 3R

### DOUBLE CARDAN ASSEMBLY

PART No.	FLANGE DIA. A	P.C.D. 4.250	No HOLES	SPIGOT DIA. F-3.125	C/LINE TO C/LINE B 3.250	TUBE SIZE 50.80 X 3.05 2.000 X 0.120	BALL REPAIR KIT PART No. CVK2A	COMMENTS
<b>4137268</b>	125.50 5.125	107.95 4.250	4	F-79.38 F-3.125	82.55 3.250	50.80 X 3.05 2.000 X 0.120	<b>CVK2A</b>	SUITS ARMY LANDROVER 6X6

Centre H Bar Yoke **3R-26-057** (3.250" C-C)  
Other centre kits are available for 3R cardan assemblies.

www.hardyspicer.com.au

Document No:	HSDSCAT
Issue:	9
Issue Date:	18/07/19

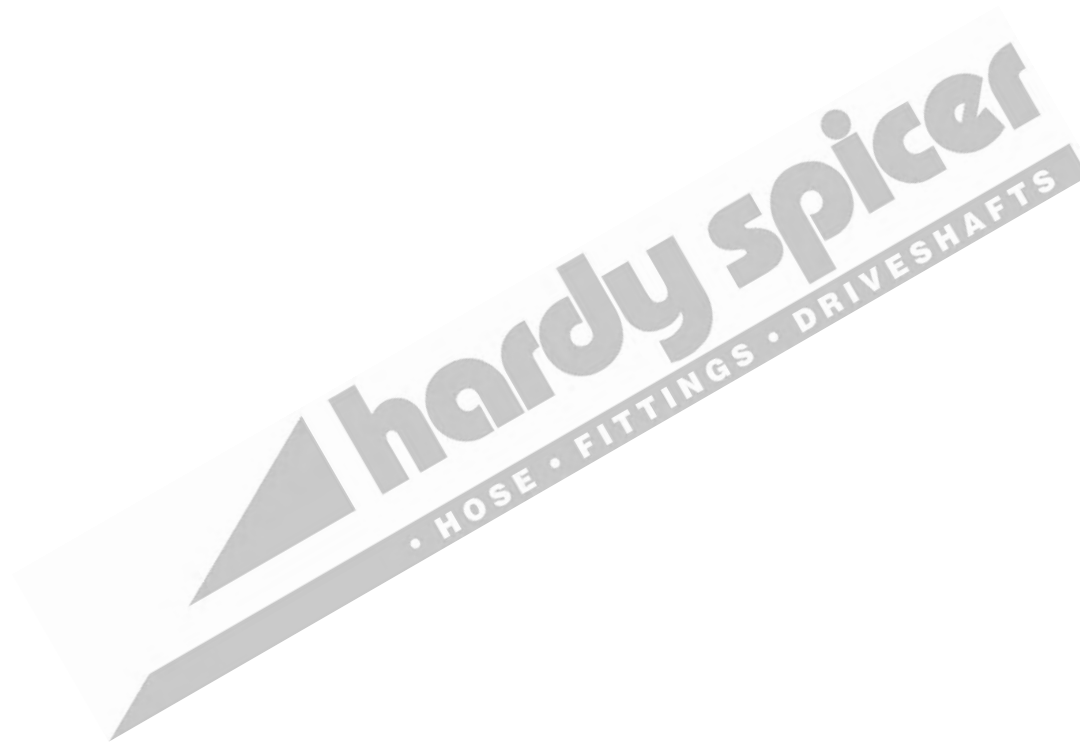

[www.hardyspicer.com.au](http://www.hardyspicer.com.au)

Document No:	HSDSCAT
Issue:	9
Issue Date:	18/07/19

## MID SHIP ASSEMBLIES

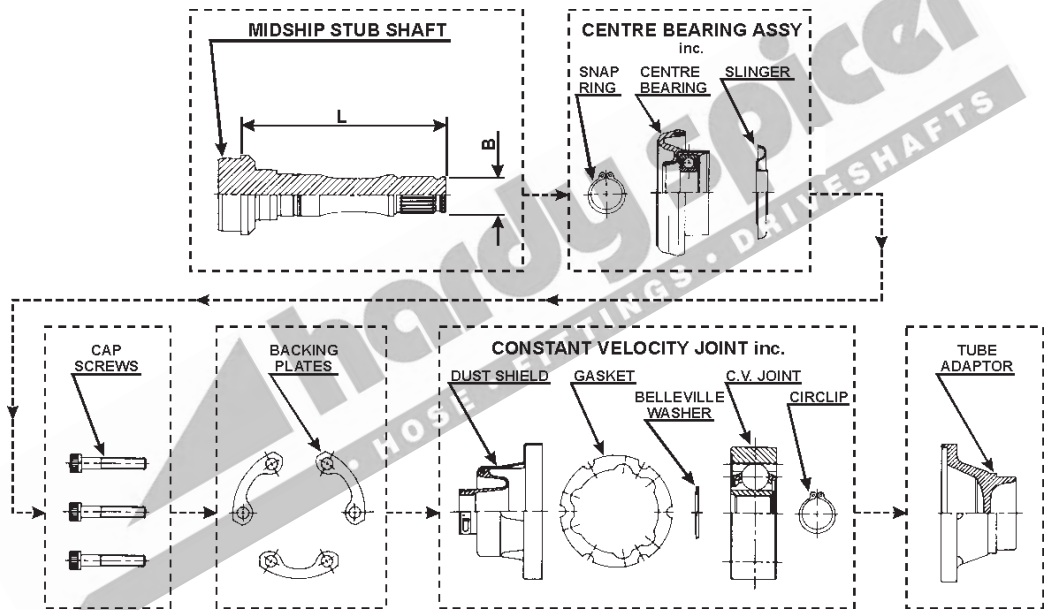

## MID SHIP ASSEMBLIES

MIDSHIP STUB SHAFT PART No.	SPLINE DIA. & No. B	END OF SPLINE TO POINT OF WELD L	TUBE PART No. & SIZE	BEARING I.D.	CENTRE BEARING PART No.	CV JOINT	TUBE ADAPTOR PART No.	COMMENTS
<b>17R-56-5821</b>	26.46-24	144.00	<b>1813-0000</b>	30.00	<b>CB-952</b>	<b>CV-856</b>	<b>679-R08</b>	CAP SCREW 6 x 608-R95 + BACKING PLATE 3 x 806-R15
<b>NLA</b>	1.083	5.433	2.250 x 0.095	1.181				
<b>2R-56-5861</b>	27.50-25	138.00	<b>1813-0000</b>	30.00	<b>CB-952</b>	<b>CV-855A</b>	<b>679-R09 #</b>	CAP SCREW 6 x 608-R95 + BACKING PLATE 3 x 806-R16
	1.083	5.433	2.250 x 0.095	1.181				
<b>2R-56-5861-25</b>	27.50-25	138.00	<b>2014-0000</b>	30.00	<b>CB-952</b>	<b>CV-855A</b>	<b>679-R09 #</b>	CAP SCREW 6 x 608-R95 + BACKING PLATE 3 x 806-R16
	1.083	5.433	2.500 x 0.083	1.181				
<b>FD-56-2918</b>	30.30-28	140.00	<b>2013-0000</b>	35.00	<b>211187X</b>	<b>CV-862</b>	<b>679-R11</b>	CAP SCREW 6 BACKING PLATE 3 x 806-R25
	1.193	5.512	2.500 x 0.095	1.378	<b>FD-30-5835</b>			
<b>FD-56-2918-30</b>	30.30-28	140.00	<b>2414-0000</b>	35.00	<b>211187X</b>	<b>CV-862</b>	<b>679-R11</b>	CAP SCREW 6 BACKING PLATE 3 x 806-R25
	1.193	5.512	3.000 x 0.083	1.378	<b>FD-30-5835</b>			

Note :  
 Replacement Boot Kit Only for CV-856 = CV-852  
 Replacement Boot Kit Only for CV-855A = CV-853  
 Replacement Boot Kit Only for CV-862 = CV-863

# Other adaptors available for larger tube diameters,  
 Refer page B4:20

www.hardyspicer.com.au

Document No:	HSDSCAT
Issue:	9
Issue Date:	18/07/19

## MID SHIP ASSEMBLIES

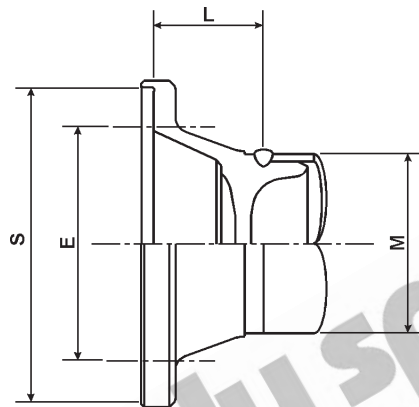

## MECHANICS

## TUBE ADAPTORS

PART No.	FLANGE	TAPPED BOLT HOLES		No. OF	TUBE O.D. & WALL THICKNESS	TUBE PART No.	ADAPTOR	SUITS CV JOINT PART No.
	INSIDE DIA.	P.C.D.	THREAD SIZE				FACE TO POINT OF WELD	
	S	E			M		L	
<b>679-R08</b>	94.00 3.701	80.00 3.150	M8 x 1.25	6	57.15 x 2.41 2.250 x 0.095	<b>1813-0000</b>	39.00 1.535	<b>CV-856</b>
<b>679-R09</b>	99.79 3.929	86.00 3.386	M8 x 1.25	6	57.15 x 2.41 2.250 x 0.095	<b>1813-0000</b>	35.00 1.378	<b>CV-855A</b>
<b>679-R10</b>	99.99 3.937	86.00 3.386	M8 x 1.25	6	63.50 x 2.41 2.500 x 0.095	<b>2013-0000</b>	35.00 1.378	<b>CV-855A</b>
<b>679-R11</b>	108.00 4.252	94.00 3.701	M10 x 1.25	6	63.50 x 2.41 2.500 x 0.095	<b>2013-0000</b>	42.00 1.654	<b>CV-862</b>
<b>679-R12</b>	99.99 3.937	86.00 3.386	M8 x 1.25	6	76.20 x 1.65 3.000 x 0.065	<b>2416-0000</b>	35.00 1.378	<b>CV-855A</b>
<b>679-R13</b>	98.00 3.858	86.00 3.386	M8 x 1.25	6	63.50 x 2.11 2.500 x 0.083	<b>2014-0000</b>	35.00 1.378	<b>CV-861</b>
<b>679-R14</b>	98.00 3.858	86.00 3.386	M8 x 1.25	6	76.20 x 2.11 3.000 x 0.083	<b>2414-0000</b>	35.00 1.378	<b>CV-861</b>

www.hardyspicer.com.au

Document No:	HSDSCAT
Issue:	9
Issue Date:	18/07/19

## TRIPOD COUPLING TYPE

### FORD

Application	Image	Part No.	PCD	Bolt Dia	OD	Bore	Width
BA FALCON 6 cyl (EXCEPT TURBO) 5 Speed MAN/4 Speed AUTO BF FALCON 6 cyl 5 Speed MAN/4 Speed AUTO		<b>GAJ-1-0</b>	96mm	12mm	134mm	50mm	35mm
BA/BF SERIES I FALCON V8 & TURBO 6 cyl BA MKII 6 cyl 6 Speed AUTO BF 6 cyl SERIES I 6 Speed AUTO		<b>GAG03-001-0</b>	105mm	12mm	142mm	56mm	32/35mm Inc. 18mm Spigot
BF FALCON SERIES II on FG FALCON		<b>GAD03-001-0</b>	110mm	12mm	148mm	56mm	32/35mm Inc. 18mm Spigot
TRANSIT		<b>GAF01-003-0</b>	105mm	12mm	142mm	56mm	32/35mm Inc. 18mm Spigot
TRANSIT		<b>GAF01-002-0</b>	120mm	14mm	160mm	64mm	40.5 / 43.5mm Inc. 20mm Spigot

### HOLDEN

Application	Image	Part No.	PCD	Bolt Dia	OD	Bore	Width
COMMODORE VS / VT V6 MANUAL (Front only)  (comes complete with 96RC-100-344 coupling, 6 bolts, 6 lock nuts & centre bush)		<b>RCA-1059</b>	96mm	12mm	133mm	49mm	30mm
COMMODORE VT SERIES 1 UP TO 6/99 V8 MANUAL (Front only)  (comes complete with 100-R337 coupling, 3 bolts, 6 lock nuts)		<b>RCA-1058</b>	100mm	12mm	149mm	41mm	36/40mm Inc. 18mm Spigot
COMMODORE VT SERIES 2 6/99 ON 5.7L V8 GEN 3 MANUAL ONLY (Front only)		<b>10005422</b>	96mm	12mm	133mm	49mm	35/38mm Inc. 18mm Spigot
COMMODORE VX-VZ VE UP TO 03/2008 V6 AUTO FRONT & REAR V6 MANUAL FRONT ONLY  (comes complete with 96RC-100-344 coupling, 6 bolts, 6 lock nuts)		<b>RCA-1060</b>	96mm	12mm	132mm	50mm	30mm
COMMODORE VX-VZ V8 MANUAL & AUTO F&R ALL VX-VE TO 03/08 REAR (EXCEPT V6 AUTO)  (comes complete with 100-R324 coupling, 3 bolts, 3 lock nuts)		<b>RCA-1061</b>	96mm	12mm	133mm	49mm	35mm

www.hardyspicer.com.au

Document No:	HSDSCAT
Issue:	9
Issue Date:	18/07/19

## TRIPOD COUPLING TYPE

### HOLDEN Cont.

Application	Image	Part No.	PCD	Bolt Dia	OD	Bore	Width
COMMODORE VE V8 FRONT & REAR CREWMAN 2004 on V8 AUTO VZ CAB CHASSIS (SOME VZ HSV APPLICATIONS)		<b>RCA-1062</b>	110mm	12mm	152mm	58mm	35/38.5mm Inc. 18mm Spigot
(comes complete with coupling, 6 bolts, 6 lock nuts & centre bush)							
COMMODORE VE V6 FRONT & REAR 3/2008 on		<b>10175274</b>	105mm	12mm	141mm	56mm	32/35mm Inc. 18mm Spigot

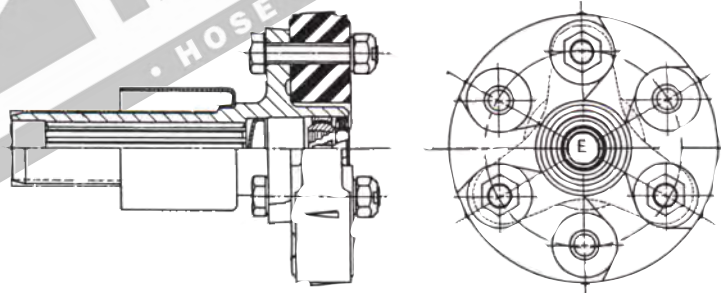

## TRIPOD

## SLIP YOKE

PART No.	No. OF SPLINES	SPLINE		GROUND SLEEVE DIA. H	C/L TO END L	LENGTH OF HOLE G	COMMENTS
		MAJOR DIA.	MINOR DIA.				
<b>96RC-3-3168</b>	27-INV	30.23 1.190	27.94 1.100	38.15 1.502	135.00 5.315	115.00 4.528	VX COMMODORE ON VT GEN3 6SPD MAN T56 96mm P.C.D. COUPLING NOT INCL.
<b>105RC-3-7747</b>	27-INV	30.23 1.190	27.94 1.100	38.15 1.502	133.00 5.236	115.00 4.528	VE (MY09) V6 3/2008 ON 105mm P.C.D. COUPLING NOT INCL.
<b>110RC-3-5146</b>	27-INV	30.23 1.190	27.94 1.100	38.15 1.502	.	.	VE COMMODORE V8 110mm P.C.D. COUPLING NOT INCL.
<b>96RC-3-3580</b>	28-INV	30.98 1.220	27.76 1.093	38.02 1.497	161.00 6.339	141.00 5.551	BA FALCON, VT V8 MAN 5.0L ONLY T5 96mm P.C.D. COUPLING NOT INCL.
<b>105RC-3-1776</b>	31-INV	35.30 1.390					FALCON 105mm P.C.D. COUPLING NOT INCL.

www.hardyspicer.com.au

Document No:	HSDSCAT
Issue:	9
Issue Date:	18/07/19



## TRIPOD COUPLING TYPE

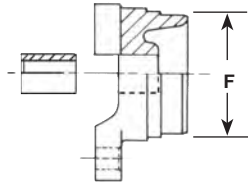

BUSH TYPE

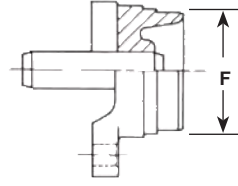

PIN TYPE

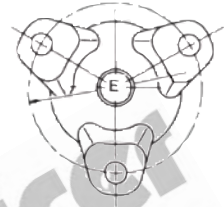

## TRIPOD

## WELD YOKE

PART No.	P.C.D. E	TUBE O.D. & WALL THICKNESS F	TUBE PART No.	TYPE	COMMENTS
96RC-26-3918	96.00 3.780	54.00 x 1.65 2.125 x 0.065		PIN	16mm PIN & SPIGOT BOLT FACES
96RC-26-U687	96.00 3.780	63.50 x 2.10 2.500 x 0.083	2014-0000	PIN	16mm PIN - NO SPIGOT FORD
96RC-26-4008	96.00 3.780	54.00 x 1.65 2.125 x 0.065		PIN	16mm PIN - NO SPIGOT
96RC-26-4018	96.00 3.780	54.00 x 1.65 2.125 x 0.065		BUSH	14mm BUSH - NO SPIGOT
96RC-26-4028	96.00 3.780	54.00 x 1.65 2.125 x 0.067		BUSH	16mm BUSH - NO SPIGOT
96RC-26-6016	96.00 3.780	60.00 x 1.70 2.125 x 0.065		BUSH	16mm BUSH - NO SPIGOT VE V6 MY07
110RC-26-7494	110.00 4.331	60.00 x 1.75 2.362 x 0.069		PIN	16mm PIN - 18mm BOLT SPIGOT
110RC-26-7495	110.00 4.331	60.00 x 1.75 2.362 x 0.069		BUSH	16mm BUSH - 18mm BOLT SPIGOT
110RC-26-U1263	110.00 4.331	63.50 x 2.10 2.500 x 0.083	2014-0000	BUSH	16mm BUSH - 18mm BOLT SPIGOT FORD
105RC-26-7745*	105.00 4.134			PIN	16mm PIN - 18mm BOLT SPIGOT VE (MY09) V6 3/2008 - FRONT
105RC-26-U686	105.00 4.134	63.50 x 2.10 2.500 x 0.083	2014-0000	PIN	16mm PIN - 18mm BOLT SPIGOT FORD
105RC-26-5267*	105.00 4.134			BUSH	16mm BUSH - 18mm BOLT SPIGOT VE (MY09) V6 3/2008 - REAR

\* WILL ALSO SUIT SOME FORDS WHEN USED WITH A TUBE COLLAR

www.hardyspicer.com.au

Document No:	HSDSCAT
Issue:	9
Issue Date:	18/07/19

# INDENT ONLY

TRIPOD COUPLING TYPE

CENTERING BUSH

Application	Image	Part No.	Length	OD	Bore
SUITS MOST COMMODORE & MOST FORD SHAFTS		UD-32-140	48.5mm	32mm	16mm
SUITS COMMODORE 14mm MAINLY FIXED G/BOX FLANGE TYPE		UD-32-138	48.5mm	32mm	14mm
SUITS FORD 16mm		UD-32-146	48.5mm	37mm	16mm
SUITS CHRYSLER 16mm		UD-32-732 #	50.8mm	31mm	16mm
SUITS BMW 14mm PIN SOME		2719-806 #	20.3mm	28mm	14mm

# INDENT ONLY

B:4-26

www.hardyspicer.com.au

Document No:	HSDSCAT
Issue:	9
Issue Date:	18/07/19